



BlackBox 130 UL

Instruction Manual



BACKBOX 130 UL (FOURTH EDITION REV 3)

June 2023

Part Number M-130-0-004-3U

COPYRIGHT

© Pulsar Measurement, 2003 - 23. All rights reserved. No part of this publication may be reproduced, transmitted, transcribed, stored in a retrieval system, or translated into any language in any form without the written permission of Pulsar Measurement.

WARRANTY AND LIABILITY

Pulsar Measurement guarantee for a period of 2 years from the date of delivery that it will either exchange or repair any part of this product returned to Pulsar Measurement if it is found to be defective in material or workmanship, subject to the defect not being due to unfair wear and tear, misuse, modification or alteration, accident, misapplication, or negligence.

DISCLAIMER

Pulsar Measurement neither gives nor implies any process guarantee for this product and shall have no liability in respect of any loss, injury or damage whatsoever arising out of the application or use of any product or circuit described herein.

Every effort has been made to ensure accuracy of this documentation, but Pulsar Measurement cannot be held liable for any errors.

Pulsar Measurement operates a policy of constant development and improvement and reserves the right to amend technical details, as necessary.

The BlackBox shown on the cover of this manual is used for illustrative purposes only and may not be representative of the actual BlackBox supplied.

CONTACT

For technical support, please contact:

Europe: supporteurope@pulsarmeasurement.com

Outside Europe: supportnorthamerica@pulsarmeasurement.com

If you have any comments or suggestions about this product, please contact:

Europe: europe@pulsarmeasurement.com

Outside Europe: northamerica@pulsarmeasurement.com

Pulsar Measurement website: www.pulsarmeasurement.com

United States

11451 Belcher Road South

Largo,

FL 33773

888-473-9546

Canada

16456 Sixsmith Drive

Long Sault, Ont.

K0C 1P0

855-300-9151

United Kingdom

Cardinal Building, Enigma

Commercial Centre

Sandy's Road, Malvern

WR14 1JJ

00 44 (0)1684 891371

CONTENTS

Chapter 1: Start Here.....	7
About this Manual	7
About the BlackBox.....	8
Functional Description	9
Product Specification.....	10
EU Declaration of Conformity	12
Chapter 2 Installation.....	13
Unpacking	13
Power Supply Requirements.....	13
Safety Symbols.....	14
Location	14
Dimensions	15
Terminal Connection Detail	16
Terminal Connections.....	18
ATEX	19
FM	19
Fuse Location.....	20
Preparation for Operation	20
Maintenance	21
Chapter 3 How To Use Your BlackBox.....	22
On board integral Keypad	22
PC Handheld Programmer	22
Handheld Communicator (Optional).....	23
Operating the Controls.....	24
Hot Keys.....	25
Menu Keys	26
Numeric Keys.....	26
Run Mode.....	27
LED's.....	27
Program Mode.....	27

How to Access Program Mode	28
Directly Editing Parameters	29
Test Mode	30
Using the RS232 Serial Interface	31
Parameter Defaults	32
Chapter 4 Programming Guide	33
Chapter 5 Parameter Guide	39
Menu System Diagrams	39
Application Menu	40
Relays Menu	41
Data Logs Menu	42
Volume Menu	43
Display Menu	44
mA Output Menu	44
Stability Menu	45
Echo Processing Menu	46
System Menu	47
Test Menu	48
Application Parameters	49
Operation	49
Dimensions	50
Remote Alarm	52
SMS Time	53
Relay Parameters	55
Alarms	56
Control	59
Common Parameters	61
Data Logs	61
Volume	62

Breakpoints.....	68
Tables.....	69
Display Parameters.....	70
Options.....	70
Failsafe.....	71
mA Output Parameters.....	72
Range.....	72
Operation.....	72
Setpoint.....	73
Limits.....	73
Trim.....	74
Failsafe.....	74
Compensation Parameters.....	75
Stability Parameters.....	76
Filters.....	76
Echo Processing Parameters.....	77
System Parameters.....	78
Passcode.....	78
System Information.....	78
Date & Time.....	79
Daylight Saving Time.....	79
Test Parameters.....	83
Simulation.....	83
Hardware.....	84
Chapter 6 Troubleshooting.....	86
Chapter 7 Disposal.....	87

CHAPTER 1: START HERE...

Congratulations on your purchase of a Pulsar BlackBox 130 Level System. This quality system has been developed over many years and represents the latest in high technology ultrasonic level measurement and control.

It has been designed to give you years of trouble-free performance, and a few minutes spent reading this operating manual will ensure that your installation is as simple as possible

About this Manual

It is important that this manual is referred to for correct installation and operation. There are various parts of the manual that offer additional help or information as shown.

Tips



TIP: Look for this icon throughout your Pulsar Measurement manual to find helpful information and answers to frequently asked questions.

Additional Information

Additional Information

At various parts of the manual, you will find sections like this that explain specific things in more detail.

About the BlackBox

The Pulsar BlackBox is a non-contact Level Control System. It has been designed to provide a new concept in low-cost maintenance-free fit and forget level measurement without any compromise on performance.

The BlackBox is ideally suited to applications where level monitoring, reporting, control, or logging is required, with or without the need for a local display. The BlackBox level system is available in a variety of different versions offering a wide choice of output options.

The BlackBox is very easy to use and may be calibrated quickly and simply via a laptop, using the software supplied with the unit, or alternatively by using the optional handheld calibrator, which connects to the unit via the RS232 interface, and provides an on-board LCD display. Certain models are also available with an optional LCD display and integral keypad fitted.

All models of the BlackBox can be used with any of the extensive range of Pulsar transducers for distances up to 131ft (40m).

The BlackBox is designed to provide you with highly reliable measurement in a robust and functional package that is easy to use and low in cost.



Functional Description

The BlackBox ultrasonic Level System sends a transmit pulse to the transducer, which emits an ultrasonic pulse perpendicular to the transducer face, and the returned echo is sent back to the BlackBox. The time taken to receive the echo is measured and the distance from the transducer face to the surface being monitored is calculated.

The BlackBox utilises the unique DATEM software (**D**igital **A**daptive **T**racking of **E**cho **M**ovement). This is a unique digital mapping technique developed especially for Pulsar's range of ultrasonic level and control systems. It gives the system edge when identifying the "true target level" in the face of competing echoes from pipes, pumps, or other obstructions.

The BlackBox can measure from 0.252 ft (0.077m) to 131 feet (40m) from the transducer to the surface being monitored, dependent on the application and transducer used.

The BlackBox can measure **level, space or distance** and provide a representative output. When fitted with the **optional display and keyboard** it can also measure and provide an output representative of **volume**. There are two user definable relays, with individual setpoints, which can be programmed to activate alarms or control functions, a mA output that can be used for remote indication purposes and a RS232 port, so that the BlackBox can be programmed or monitored remotely by a PC or other equipment.

The BlackBox can be programmed either by PC, via the RS 232 Serial Interface, using the supplied software (standard) or by handheld calibrator (optional) which is connected to the BlackBox via the RS 232 interface.

Those units fitted with the optional on-board display can be programmed via the integral keyboard.

All the parameters are stored in non-volatile memory, so are retained in the event of power interruption.

Product Specification

PHYSICAL

Outside dimensions	5.63 x 5.91 x 2.5" (143 x 150 x 63.5 mm)
Weight	Nominal 1.54lbs (0.7 kg)
Enclosure material/description	ABS base with Polycarbonate lid, flammability rating UL94HB
Cable entry detail	Underside fitted with 3 x M20, nylon cable glands suitable for 6 – 12mm cable
Transducer cable extensions	3 conductor 20AWG screened
Nominal separation	1000 m (3,280 ft.). 500m (1,640 ft.) for dBR16 & dBR8, for greater distances consult Pulsar

ENVIRONMENTAL

Relative Humidity (IP rating)	IP67 (NEMA 4X enclosure) <35°C (95°F) at 93% relative humidity. Pollution Degree 2
Max. & min. temperature (electronics)	-20 °C to +50 °C (-4°F to 120°F)
Flammable atmosphere approval	Safe area: compatible with approved dB transducers (see transducer spec' sheet)
UL	File Number E257330
CE Approval	See EU Declaration of Conformity

PERFORMANCE

Accuracy	0.25% of the measured range or 0.24" (6 mm) (whichever is greater)
Resolution	0.1% of the measured range or 2 mm (0.08") (whichever is greater). ±2mm for dBR16 & dBR8
Max. range	0.1% of the measured range or 0.08" (2 mm) (whichever is greater). ±2mm for dBR16
Min. range	Dependent upon transducer (minimum 0.2521ft (0.077m) dBR16 & dBR8)
Rate response	Fully adjustable

OUTPUTS

Analogue output	Isolated (floating) or non-isolated output of 4-20 mA or 0-20 mA into 1KΩ (user programmable and adjustable) 0.1% resolution
Display	2 x 12 alpha numeric
Serial Port	RS232 for programming and data extraction
Volt free contacts, number, and rating	5 form "C" (SPDT) rated at 5A at 115V/240V AC

ECHO PROCESSING

Description	DATEM (D igital A daptive T racking of E cho M ovement)
Technology	Ultrasonic and FMCW Radar

PROGRAMMING

On-board programming	By integral keypad
Programming security	Via passcode (user selectable and adjustable)
Programmed data integrity	Via non-volatile RAM
PC Programming	Via RS232 using supplied software
Remote programming	via RS232 using optional hand-held calibrator

SUPPLY

Power Supply	115 VAC +5% / -10% 50/60 Hz, DC 10 - 28V 10W maximum power (typically 5W)
Mains fuse (F1)	100 mA T at 115V AC
DC (Battery) (F2)	1A Thermal (self-resetting after power removed). Not user replaceable
Transducer (F3, F5)	Little fuse 242 series 100mA Part No. 0242.100. This fuse is not user replaceable and has a 4000A breaking capability to comply with certification of the Exm version of dB series transducers.

REMOTE COMMUNICATOR

Power Supply	Power supplied via BlackBox RS232 interface.
---------------------	--

Pulsar Measurement operates a policy of constant development and improvement and reserve the right to amend technical details, as necessary.

EU Declaration of Conformity



EU DECLARATION OF CONFORMITY

PULSAR *Blackbox series*

This declaration of conformity is issued under the sole responsibility of the manufacturer.

Relevant Directive(s)	2014/30/EU - EMC Directive and its amending directives. 2014/35/EU - Low Voltage Directive and its amending directives. 2011/65/EU - RoHS Directive and its amending directives.
Manufacturer's Name	Pulsar Process Measurement Ltd.
Manufacturer's Address	Cardinal Building, Enigma Business Commercial Centre, Sandy's Road, Malvern, Worcestershire, WR14 1JJ, UK.
Apparatus	Pulsar Blackbox 130 range.
Models	130, 133, 134, 135, 136.
Type of Equipment	Measurement and process control.
Standards Applied	EN 61010-1:2010+A1:2019 Safety requirements for electrical equipment for measurement, control and laboratory use. EN 61326-1:2013 EMC, equipment class industrial.

I declare that the apparatus named above has been tested and complies with the relevant sections of the above referenced standards & directives.

Signed for and on behalf of:

A handwritten signature in black ink, appearing to read "Tim Brown", is written over a horizontal line.

Date: 1st April 2021.

Rev. 5.2

Name & function:

Tim Brown, Electronics Engineer

Pulsar Process Measurement Ltd.

CHAPTER 2 INSTALLATION

Unpacking

Important Notice

All shipping cartons should be opened carefully. When using a box cutter, do not plunge the blade deeply into the box, as it could potentially cut or scratch equipment components. Carefully remove equipment from each carton, checking it against the packing list before discarding any packing material. If there is any shortage or obvious shipping damage to the equipment, report it immediately to Pulsar Measurement.





Power Supply Requirements

The BlackBox can operate from AC supply or from a DC battery and is designed for use in temperatures between -4°F to +140°F (-20°C to +50°C). The **AC** is **115V +5%/-10%**. The **DC** is **10-28V**. In all cases the Blackbox will typically consume 5W of power, with a maximum of 10W. If the BlackBox has both an AC and DC supply available then the AC supply source will be automatically sensed and used, should the AC supply be removed for any reason then the DC supply will take over.

The AC and DC wiring should be completed using either 16 – 14AWG (1.5–2.5mm²) stranded or 16 – 14AWG (1.5–4mm²) solid wire, with all terminals being tightened to 4.5in. lbs. (0.5Nm). An external supply isolator/circuit breaker (AC or DC) must be fitted and labelled to identify the instrument to which it refers.

Safety Symbols

Detailed below are descriptions and meanings of safety/warning symbols that are used on the FlowCERT and in this manual:

SYMBOL	DESCRIPTION
	DIRECT CURRENT (DC)
	ALTERNATING CURRENT (AC)
	PROTECTIVE CONDUCTOR TERMINAL
	CAUTION (Refer to accompanying Documents)

Location

All electronic products are susceptible to electrostatic shock, so follow proper grounding procedures during installation.

The BlackBox must be mounted in a non-hazardous (safe) Area.

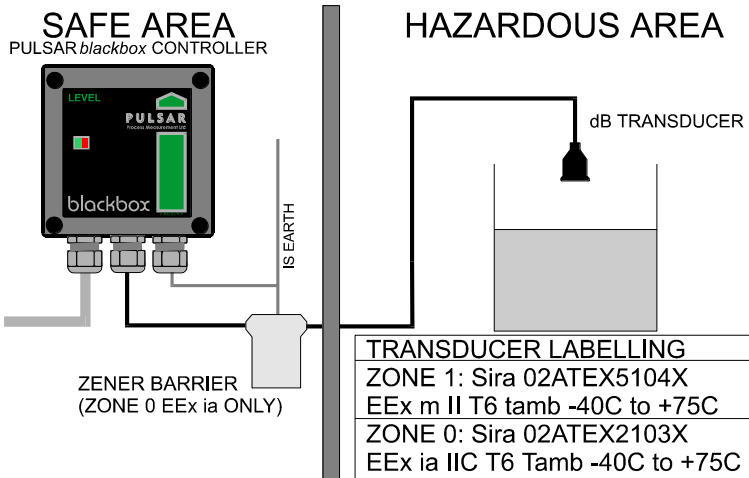

When choosing a location to mount the enclosure, bear in mind the following:

- Easy access to the enclosure is maintained.
- The mounting surface is vibration-free.
- The ambient temperature is between -20°C and 50°C (-4°F and 120°F).
- There should be no high voltage cables or inverters close by.

Dimensions

The dimensions of the mounting holes are as shown below:

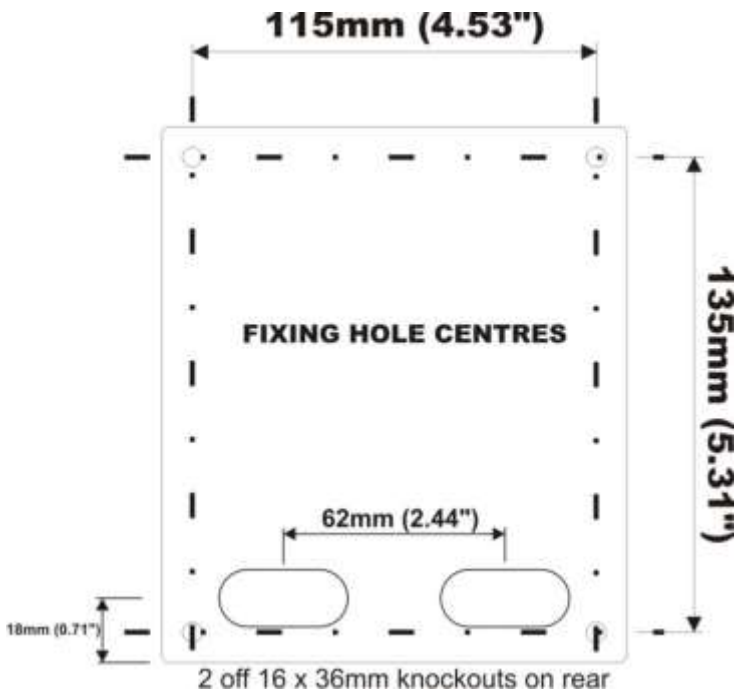

The BlackBox should be mounted by drilling four holes suitable for size 8 screws (length and type to suit your application) And fix all four screws by removing the top cover to access the pre-moulded mounting holes which are in the base of the enclosure under the lid retaining screws.

The full dimensions of the enclosure are as shown below.

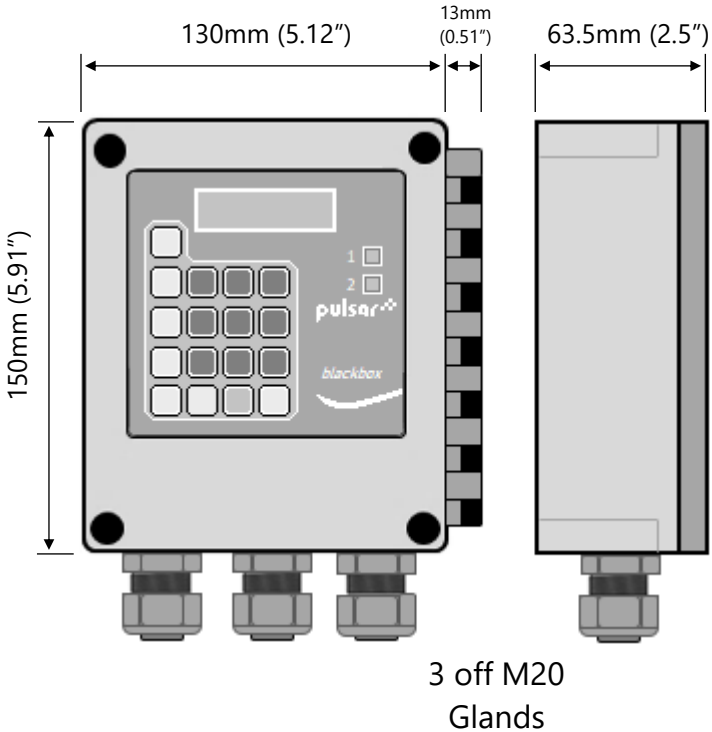

Cable Entry

There are 3 x M20 cable glands, suitable for 6 – 12mm cables, fitted to the base of the BlackBox enclosure.

Terminal Connection Detail

The terminal strip is as detailed below. There is also a wiring diagram attached to the board directly underneath the terminal strip.

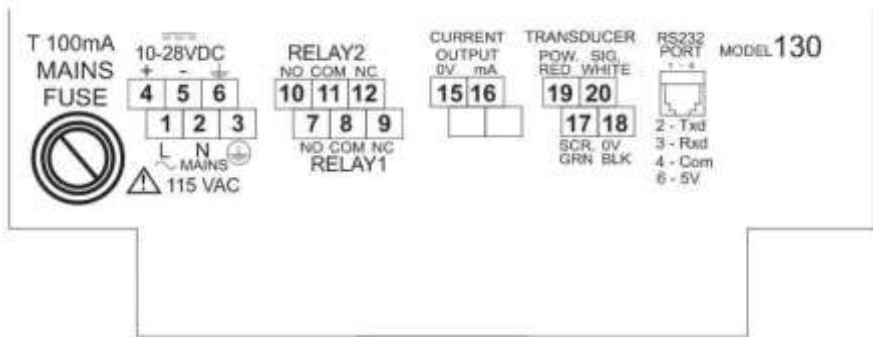

Important Notice

All cable glands should be tightened to the manufacturer's specifications. The terminal compartment cover screws should be tightened to 0.5Nm. Care should be taken not to over tighten the screws.

Terminal Connections

Power

The BlackBox can operate from mains AC and automatically from a DC power source or battery backup, in the event of power failure, or can be operated permanently from DC or batteries.

The AC and DC wiring should be completed using either 16 – 14AWG (1.5–2.5mm²) stranded or 16 – 14AWG (1.5–4mm²) solid wire.

An external supply isolator/circuit breaker (AC or DC) must be fitted and labelled to identify the instrument to which it refers.

Transducer

The transducer should be installed, and connected, in accordance with the installation instructions contained in the Transducer User Guide.

The entire range of standard dB transducers are certified for use in hazardous areas and different models, for each, are available for use in EEx m (Zone 1) or EEx ia (Zone 0).

Wire the transducer to the BlackBox transducer terminals as detailed below:

Red = Power (Terminal 19)

White = Signal (Terminal 20)

Black = 0 volts (Terminal 18)

Green (screen) = SCR (Terminal 17)

When using 2 core screened extension cable, the Black and Green wires of the transducer should be connected to the screen of the extension cable and connected to the 0 volts' terminal (Terminal 18).

If splicing, it is recommended using a junction box with standard twisted, shielded pair at 20 AWG.

When using 2 core screened extension cable, the Black and Green wires of the transducer should be connected to the screen of the extension cable and connected to the 0 volts' terminal (Terminal 18).

ATEX

For **EEx m (Zone 1)** applications a transducer certified to **Sira 02ATEX5104X** is used, and must be supplied via a 4000A breaking fuse, which is fitted as standard to the BlackBox level controller.

For **EEx ia (Zone 0)** a transducer certified to **Sira 02ATEX2103X** is used, which must be connected to the BlackBox via an external Zener barrier.

FM

For **EEx m (Zone 1)** applications a transducer certified to **FM Class I Div 1 Group A, B, C & D, ClassII Div 1 Group E, F & G, Class III** is used, and must be supplied via a 1500A breaking fuse, which is fitted as standard to the blackbox level controller.

Restrictions do not use in the presence of these groups of Chemicals, Aliphatic Hydrocarbons, Ketones or Esters

For **EEx ia (I.S.)** a transducer certified to **FM Class I Div 1 Group A, B, C & D, ClassII Div 1 Group E, F & G** is used, which must be connected to the blackbox via an external Zener barrier.

See transducer label for certification details.

Relay Outputs

The two relays can be programmed to a variety of alarm & control functions. The relay contacts are all rated at 2A at 240V AC. All connections should be such that the short circuit capacity of the circuit to which they are connected, is limited by fuses rated so that they do not exceed the relay rating.

Current Output

This is an isolated active mA output of 4 - 20mA or 0 - 20mA, with an option of a passive mA output. The load should not exceed 1K Ω .

RS232 Serial Interface

The serial interface is used to program the BlackBox either via a PC (standard) using the software supplied or alternatively using the handheld calibrator (optional).

Fuse Location

The mains fuse is located, on the bottom board, to the left of the mains terminals, as illustrated below.

Important Notice

Before applying AC power (mains), make sure the supply is 115 VAC +5% / -10%
Never operate the BlackBox with terminal access exposed.

An external switch or circuit breaker should be installed near to the BlackBox to allow the supply to be removed during installation and maintenance. In addition, the relay contacts should also have a means of isolating them from the Blackbox.

Interconnecting cables must be adequately insulated in accordance with local regulations. Strip back 30 mm of the outer insulation of the cable. Strip 5 mm of insulation from the end of each conductor. Twist all exposed strands of the conductor together. Insert the stripped conductor into the terminal block as far as it will go and tighten the terminal block screw. Ensure that all strands are firmly clamped in the terminal block and that there is no excess bare conductor showing, and no stray strands.

Important Notice

If the equipment is installed or used in a manner not specified in this manual, then the protection provided by the equipment may be impaired.

Preparation for Operation

Before switching on, check the following:

- ✓ The BlackBox is mounted correctly and is in a 'safe' area.
- ✓ The power supply is correctly installed.
- ✓ The relays are connected correctly.

Maintenance

There are no user serviceable parts inside your Blackbox, except the mains power fuse. If you experience any problems with the equipment, then please contact Pulsar Process Measurement for advice.

Important Notice

Please note that the on-board Lithium battery, mounted to the processor PCB, is not user serviceable.

To clean the equipment, wipe with a damp cloth. Do not use any solvents on the enclosure or transducer.

Important Notice

The unique DATEM software comes into operation as soon as power is applied, and is designed to monitor a **moving level** or **target** with the **transducer** in a **fixed position**.

If, after any period of use, it should become necessary to move the transducer, for any reason, from its original operating position, switch off the Blackbox, before proceeding, to prevent any undesirable updates to the DATEM trace. If after moving the transducer the reading is not as expected, please refer to **Chapter 6 Troubleshooting**.

CHAPTER 3 HOW TO USE YOUR BLACKBOX

To view or change parameter values one of the following methods must be used:

On board integral Keypad

The onboard keypad can be used to program the BlackBox directly, or view parameters. Simply enter the passcode **1997** and press enter, and you will be taken into program mode where all parameters can viewed and changed to suit your application.

PC Handheld Programmer

Your BlackBox 130 comes complete with the PC Handheld Programmer software, contained on CD. Insert the CD into the CD drive of the PC intended to be used to carry out the programming of the BlackBox and install the software, following the on-screen instructions.

Once the software is installed connect the computer via its serial port to the BlackBox RS232 serial interface RJ11 connector, located on the terminal connector strip, inside the BlackBox enclosure. Double click the 'Handheld Programmer' icon, installed on your desktop and the PC will automatically connect to the Blackbox.

Once connected you will briefly see the message illustrated on the display below which, after connecting successfully, will then change to display the current measurement, dependent on mode and measurement unit's chosen. When using the PC Handheld Programmer software, keypad input can be achieved by using a 'mouse' or similar device to place the cursor over the relevant key followed by a 'left' click, alternatively numeric detail can be entered directly from the PC keyboard as can 'ENTER' and 'CANCEL' (Esc. Key).

Communication Port Configuration

If the PC Handheld Programmer fails to connect to the BlackBox unit you may need to change the communications port that is being used, to do this 'right click' on the PC Handheld Programmer keypad and a 'pop up' menu will appear allowing you to select the appropriate communications port.



Handheld Communicator (Optional)

The optional Handheld communicator can be used to programme any number of Blackbox units and works in a similar way to the PC Software. Connect the Handheld Communicator, with the cable supplied to the RS232 interface via the RJ11 connector located on the terminal connector, inside the BlackBox enclosure. Once connected you will briefly see a message, like that as seen when using the PC Software which, after connecting successfully, will then change to display the current measurement, dependent on mode and



measurement unit's chosen.

Operating the Controls

Display

Whilst in the Run Mode it will display the current level or volume reading and its units of measurement, along with the mA output and status messages with regards to the communication status and Fail-Safe Mode.

When in Program mode, the display is used to read information on the menu system, the parameter number and parameter details and values, which can be entered.

During Test Mode the display is used to monitor the simulated level or volume and mA output.



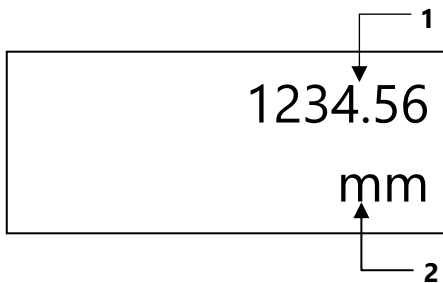



- 1) **Main Display**, 12-digit alpha numeric display:
Run Mode: current measurement displayed, dependent on measurement unit's chosen, and value of Hot Key function selected.
Program Mode: displays parameter number and values entered for parameters.
Test Mode: displays simulated level or volume.



- 2) **Auxiliary Display**, scrolling 12-digit alpha numeric display
Run Mode: displays units, totaliser or status messages on communications, detail of Hot Key function selected.
Program Mode: displays Menu and Sub Menu headings, parameter details and options.





Hot Keys

There are five hot keys on the keypad, which can be used to quickly access common parameters for viewing only, while in Run Mode. Pressing the hot key once will display the first parameter, then repeated pressing will display the others, then the BlackBox reverts to Run Mode. In program mode, they have different functions, the functions are shown below.

HOT KEY	RUN MODE	PROGRAM MODE
	Not used with BlackBox 130.	Not used with BlackBox 130.
	Displays echo confidence, echo strength, H.A.L.L., average noise, peak noise, or temperature.	Not used with BlackBox 130.
	Not used with BlackBox 130.	Reset parameter to default setting
	Instantaneous mA output	Not used with BlackBox 130.
	Dependant on application displays Distance, Level, Space or Volume (optional) in units of measurement.	Not used with BlackBox 130.
	Not used with BlackBox 130	Takes you to the last parameter edited when you first enter program mode.
	Shows details of function type, firmware revision and serial number	Enter decimal point.

Menu Keys

The menu keys have the following functions:

Hot Key	function
	1) Arrow keys for moving left and right around the menu system.
	2) Used in test mode to simulate the level moving up and down.
	1) Used to confirm each action (for example select a menu option) or when entering a parameter number or value 2) Used to confirm questions asked by your BlackBox, such as before restoring factory defaults
	Used to navigate up a level in the menu system, and back to run mode. Used to cancel a value entered in error.

Numeric Keys

These keys are used for entering numerical information during programming.

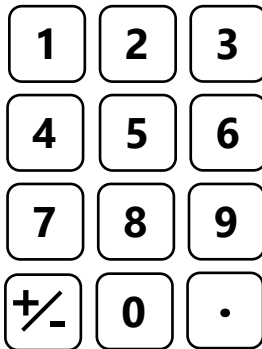

There are two main operating modes for your BlackBox, **Run Mode** and **Program Mode**. There is also a **Test Mode**, used for checking the set-up. All modes are now described.

Run Mode

This mode is used once the BlackBox has been set up in program mode. It is also the default mode that the unit reverts to when it resumes operation after a power failure. When the Blackbox is switched on for the first time, it will provide an output proportional to the distance from the transducer to the target, in metres. All relays by default are switched off.

If either the PC Programming Software (standard) or the Handheld Calibrator (optional), are connected to the BlackBox, via the RS232 interface, while the Blackbox is in the RUN mode then the current measurement will be displayed, dependent on mode and measurement unit's chosen. Models fitted with the optional LCD display and integral keypad will also display the current measurement, dependent on mode and measurement unit's chosen. After programming is complete, any relays that are set will operate when the measurement reaches the relevant setpoint.

LED's

There are two LED's that can be seen through the lid of the BlackBox enclosure, which will indicate the operational **status** of the **relays** whilst in **RUN** mode, as follows:

LED 1	LED 2	RUN MODE
Off	Off	Relays are in their OFF state
Constant On	Off	Relay 1 is in its ON state
Off	Constant On	Relay 2 is in its OFF state

Program Mode

This mode is used to set up the BlackBox or change information already set. You must use either the on-board keypad (standard) or alternatively the unit can be set up with a Handheld Calibrator (optional), which must be connected to the BlackBox via the RS 232 Serial Interface.

Entering a value for each of the parameters that are relevant to your application provides all the programming information.

How to Access Program Mode

To enter **program mode**, you simply enter the passcode, via the keypad, followed by the ENTER key. The **default passcode** is **1997**, so you would press the following:



Important Notice

There is a time-out period of 15 minutes when in program mode, after which time run mode will be resumed if you do not press any keys.

There are two means of editing parameters, directly or using the menu system. Each is now described.

Using the Menu System

The menu system has been designed to make the changing of parameters very simple. There are two levels of menu: **Main Menu** and **Sub Menu**.

On the display there is a line of text that shows the menu system. Pressing the arrow keys scrolls the display between the top-level menu items, (as shown below, starting at Application).

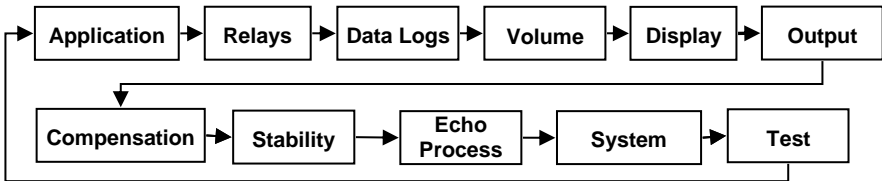

As you press the cursor keys to scroll left and right between these, you can press ENTER at any time to select it and take you to the sub-menu. Each of these options, along with their sub-menus is described in Chapter 5, **Parameter Guide**. When you move down into the sub-menu, you can scroll round using the arrow keys, press ENTER to go to the required section of parameters.

Once you have reached the relevant section, scroll through the parameters, and enter the necessary information. To enter the information, use the numeric keys and press ENTER and you will see the message "**Saved!**". If you press CANCEL, then no change will be made, and the message "**Unchanged!!**" will be displayed.

When you have finished, press CANCEL to go back to the previous level. When you have reached the top level, then the BlackBox will ask for confirmation before allowing you to go back into run mode. This is done by pressing ENTER at the display prompt.

Directly Editing Parameters

If you already know the number of the parameter, that you wish to look at or edit, simply type the number in at any time while you are in the menu system. Thus, if you are in either the menu or sub-menu level by pressing a numeric key, you can enter the parameter number directly and jump straight there. You cannot type a parameter number whilst at parameter level, only at one of the two menu levels.

When you are at a parameter, the text line rotates automatically displaying the parameter name, number, the applicable units, and the maximum and minimum figure you can enter. The top line shows the value you are setting.

Once you have accessed a parameter, you can either just look at it, or change it.

Once a parameter has been changed, press **ENTER** and you will see the message "**Saved!**". If you press CANCEL, then no change will be made, and the message "**Unchanged!!**" will be displayed.



TIP: You can jump straight to the last parameter you edited, by pressing the +/- key when you first enter program mode.

Test Mode

Test mode is used to simulate the application and confirm that all parameters and relay setpoints have been entered as expected. During simulation, there is a choice of whether the relays will physically change state (hard simulation) or not (soft simulation), the LED's will always change state to indicate that the relay setpoints have been activated, and the output will change in accordance with the chosen mode of operation. If you wish to test the logic of the system that the **relays are connected** to then select **hard simulation**, but if you **do not want to change the relay state**, then select a **soft simulation**.

There are two simulation modes, **automatic** and **manual**. **Automatic** simulation will move the level up and down between empty level and maximum span, whereas **manual** simulation will allow **you** to move the level up and down using the arrow keys.

To enter simulation, first go to **program mode**. Then, using the menu system, select menu item '**Test**' then sub-menu item '**Simulation**'. Simply change the value of the parameter **P980** to one of the following:

- 1= Manual soft simulation
- 2= Automatic soft simulation
- 3= Manual hard simulation
- 4= Automatic hard simulation

To return to program mode, press **CANCEL**, and test mode will end.

When in **manual** simulation, by default test mode will move the level by 0.25m steps. Altering the **increment (P981)** will change this value.

In **automatic** mode, the rate at which the level moves up and down is set by the **increment (P981)** in metres and the **rate (P982)** in minutes, which can be changed to make the level move up and down faster. E.g., if **increment (P981)** is set for 0.25m and **rate (P982)** is set to 1 min then the level will increase or decrease at a rate of 0.25m/min. To make the simulated level move slower, decrease the value in **increment (P981)** or increase the value in **rate (P982)**. To make the simulated level move faster, increase the value in **increment (P981)** or decrease the value in **rate (P982)**.

LED's

There are two LED's that can be seen through the lid of the BlackBox enclosure, which will indicate the operational status of the relays whilst in RUN mode, as follows:

LED 1	LED 2	RUN MODE
Off	Off	Relays are in their OFF state
Constant On	Off	Relay 1 is in its ON state
Off	Constant On	Relay 2 is in its OFF state
Constant On	Constant On	Relay 1 and 2 in their ON state

Using the RS232 Serial Interface

The RS232 serial interface is used to program the Blackbox, and communicate between the Blackbox and a PC using the optional BlackBox PC and other associated Pulsar software packages, to obtain information such as data logging and view echo traces upload, download and save parameter files. In addition, it can also be used to control or obtain information using a standard PC or other computer-based equipment. To do so, the settings for control are as follows: **baud rate 19200, 8 data bits, no parity, 1 stop bits.**

The device should be connected to the RS232 Interface via the RJ11 connector as shown in [Chapter 2 Installation](#).

Parameter Defaults

Factory Defaults

Important Notice

When first installing the BlackBox, or subsequently moving or using the unit on a new application, before proceeding to program the unit for its intended application it is recommended that you ensure that all parameters are at their default values by completing a Factory Defaults P930, as described in Chapter 5 Parameter Guide.

When you first switch the BlackBox on it will provide an output proportional to the **distance** from the face of the transducer to the surface. All relays are set OFF.

The **date** (P931) and **time** (P932) in the Blackbox were set at the factory, but may need checking, and amending if, for example the application is in a time zone other than GMT, see Chapter 5 Parameter Guide for full details.



TIP: In some applications, it is simplest to empty the vessel, take a reading from the BlackBox and then setup the empty level to this figure.

Once you are satisfied with the installation, and the BlackBox is reading what you would expect in terms of distance from the face of the transducer to the material level, then you can proceed with programming, for the intended application. It is sensible to program all the required parameters at the same time. The system will be then set-up.

Note: *that the span is automatically calculated from the empty level, so the empty level should be entered first.*

CHAPTER 4 PROGRAMMING GUIDE

Example 1 Level Measurement

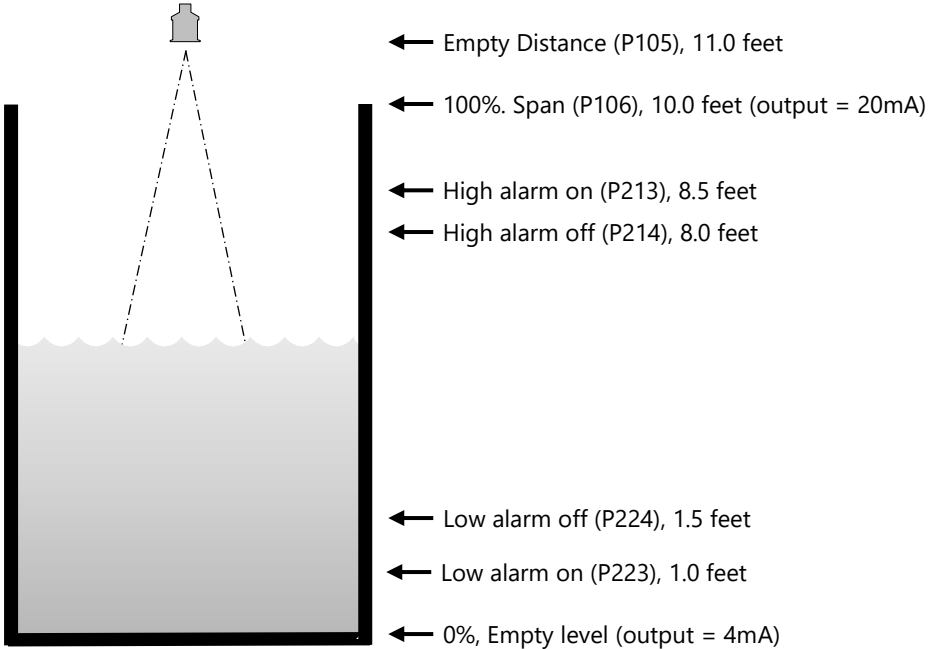

In this example, the Blackbox and dB6 is being used to monitor a moving level within a vessel and is required to provide a 4 to 20mA output proportional to the level, over a range of 10.0 feet. In addition, when the level rises to 8.5 feet, Relay '1' is required to give a high alarm and rest when the level falls to 8.0 feet. If the level should fall to 1.0 feet, then Relay '2' is to give a low alarm and reset once the level rises to 1.5 feet.

To program the BlackBox for this **Example**, proceed as follows.

Access the **Program Mode**, key in the **passcode** 1997 and press **ENTER**

Using the menu system access the parameters, as detailed below, and select the relevant options and **ENTER**

PARAMETER	SELECTED VALUE
P100 Mode	2 = Level
P101 Xducer	2 = dB6
P104 Measurement Units	4 = Feet
P105 Empty Distance	3.5
P106 Span	3.2
P210 Relay 1 Type	1 = Alarm
P211 R1 Function	1 = Level
P212 R1 ID	2 = High
P213 R1 Setpoint 1	8.5
P214 R1 Setpoint 2	8
P220 Relay 2 Type	1 = Alarm
P221 R2 Function	1 = Level
P222 R2 ID	4 = Low
P223 R2 Setpoint 1	1.0
P224 R2 Setpoint 2	1.5

Programming is now complete, and the unit can be returned to the run mode, press **CANCEL** until **Run Mode?** Is displayed on the display press **ENTER**, and the BlackBox will return to the **Run Mode**.

Important Notice

The 4 to 20mA output will be automatically set to the value of P106 Span, with 4mA being representative of 0% of Span (zero level) and 20mA 100% of Span (Full level).

Example 2 Alternating Control (Pump Down)

A sump is typically used to temporarily hold water or effluent, and when the level reaches a specific point, the sump is pumped down, with the fluid being transferred to another process.

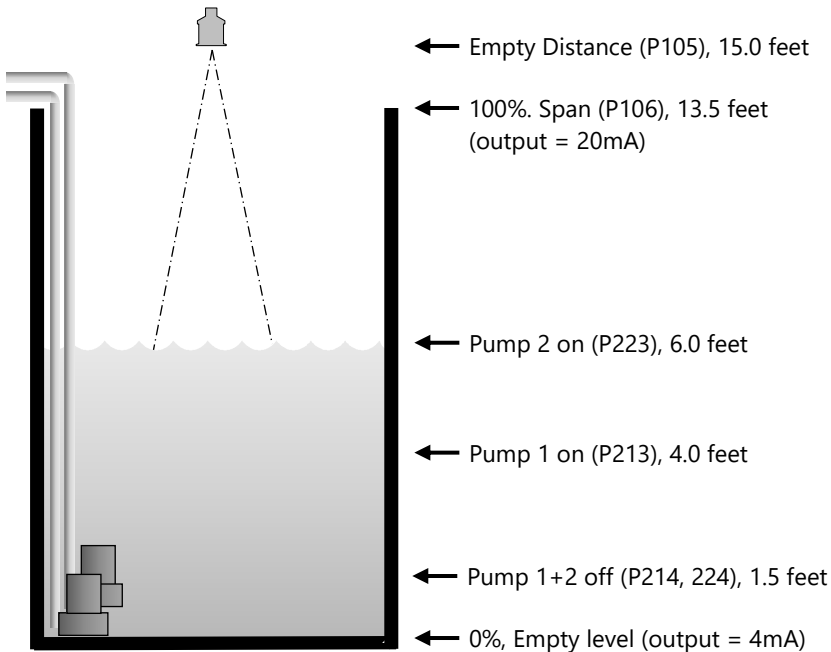

In this example a Blackbox with dB6 is being used to control pumps on a **pump down** application, there are two pumps, and the **duty** pump is to be **alternated** between the pumps.

This will operate as follows. During normal operation, **pump 1** will come on at 4.0 feet, and pump down to 1.5 feet. The setpoints are then shifted to **pump 2**, which will come on first next time.

During peak periods, when **pump 1** cannot cope, **pump 1** will come on at 4.0 feet, **pump 2** will come on at 6.0 feet, and pump down to 1.5 feet. The setpoints are then shifted to **pump 2**, which will come on **first next time**. The 4 to 20mA output will be representative of level.

To program the BlackBox for this **Example**, proceed as follows.

Access the **Program Mode**, key in the **passcode** 1997 and press **ENTER**

Using the menu system access the parameters, as detailed below, and select the relevant options and **ENTER**

PARAMETER	SELECTED VALUE
P100 Mode	2 = Level
P101 Xducer	2 = dB6
P104 Measurement Units	4 = Feet
P105 Empty Distance	15.0
P106 Span	13.5
P210 Relay 1 Type	2 = Control
P211 R1 Function	1 = General
P212 R1 ID	2 = Alternate
P213 R1 Setpoint 1	4.0
P214 R1 Setpoint 2	1.5
P220 Relay 2 Type	2 = Control
P221 R2 Function	1 = General
P222 R2 ID	2 = Alternate
P223 R2 Setpoint 1	6.0
P224 R2 Setpoint 2	1.5

Programming is now complete, and the unit can be returned to the run mode, press **CANCEL** until **Run Mode?** Is displayed on the display press **ENTER**, and the BlackBox will return to the **Run Mode**.

Important Notice

The 4 to 20mA output will be automatically set to the value of P106 Span, with 4mA being representative of 0% of Span (zero level) and 20mA 100% of Span (Full level).

Example 3 Volume

A cylindrical tank with a diameter of 2m and a flat base that is typically used to temporarily hold liquid, and you wish to know the volume of liquid. You also require a high and low alarm.

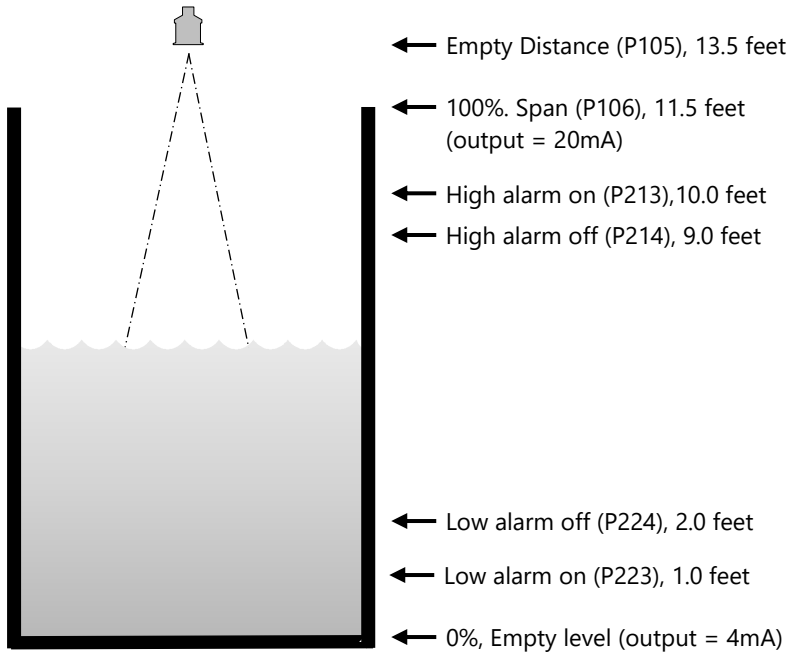

In this example, if the level rises to 10.0 feet, then the high-level alarm (relay 1) will come on until the level drops to 9.0 feet. If the level falls to 1.0 feet, then the low-level alarm (relay 2) will come on until the level rises to 2.0 feet.

The display will show the volume of fluid in the tank and the mA output will be representative of Volume where 4mA = empty (0%) and 20mA = Max Volume (100%).

To program the BlackBox for this **Example**, proceed as follows.

Access the **Program Mode**, key in the **passcode** 1997 and press **ENTER**

Using the menu system access the parameters, as detailed below, and select the relevant options and **ENTER**

PARAMETER	SELECTED VALUE
P100 Mode	5 = Volume
P101 Xducer	2 = dB6
P104 Measurement Units	4 = Feet
P105 Empty Distance	13.5
P106 Span	11.5
P210 Relay 1 Type	1 = Alarm
P211 R1 Function	1 = Level
P212 R1 ID	2 = High
P213 R1 Setpoint 1	10.0
P214 R1 Setpoint 2	9.0
P220 Relay 2 Type	1 = Alarm
P221 R2 Function	1 = Level
P222 R2 ID	4 = Low
P223 R2 Setpoint 1	1.0
P224 R2 Setpoint 2	2.0
P600 Vessel Shape	0 = Cyl. Flat Base
P601 – P603 Vessel Dimensions	Enter dimensions as required
P604 Calc. Volume	Shows the volume as calculated by the BlackBox
P605 Volume Units	Select as required
P606 Correction Factor	Enter value of any correction factor e.g., specific gravity of material
P607 Max Volume	Displays the Max Volume as calculated by the BlackBox

Programming is now complete, and the unit can be returned to the run mode, press **CANCEL** until **Run Mode?** Is displayed on the display press **ENTER**, and the BlackBox will return to the **Run Mode**.

CHAPTER 5 PARAMETER GUIDE

This chapter describes all the parameters in your BlackBox, in the order they appear in the menu system.

Menu System Diagrams

Shown below is a set of charts to show you how all the various parts can be found using the menu system.

Top Level Menu

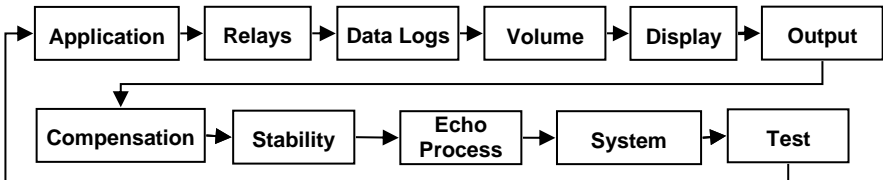

Application Menu

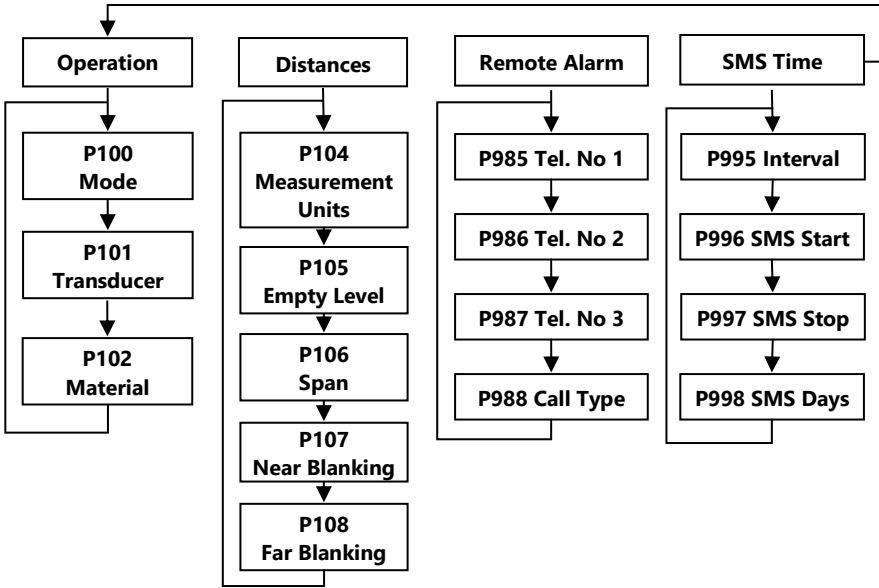

Relays Menu

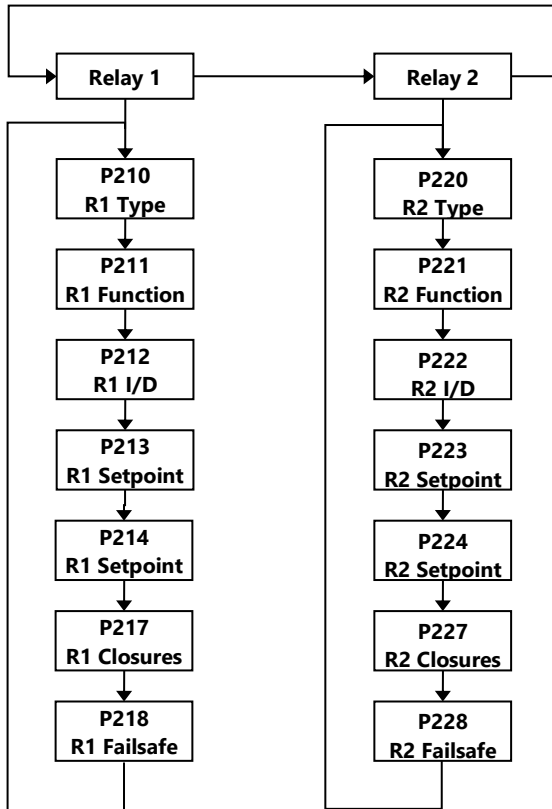

Data Logs Menu

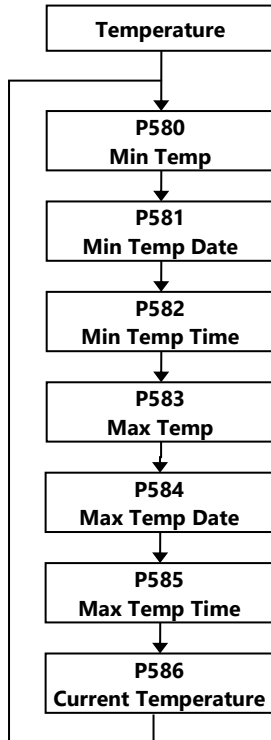

Volume Menu

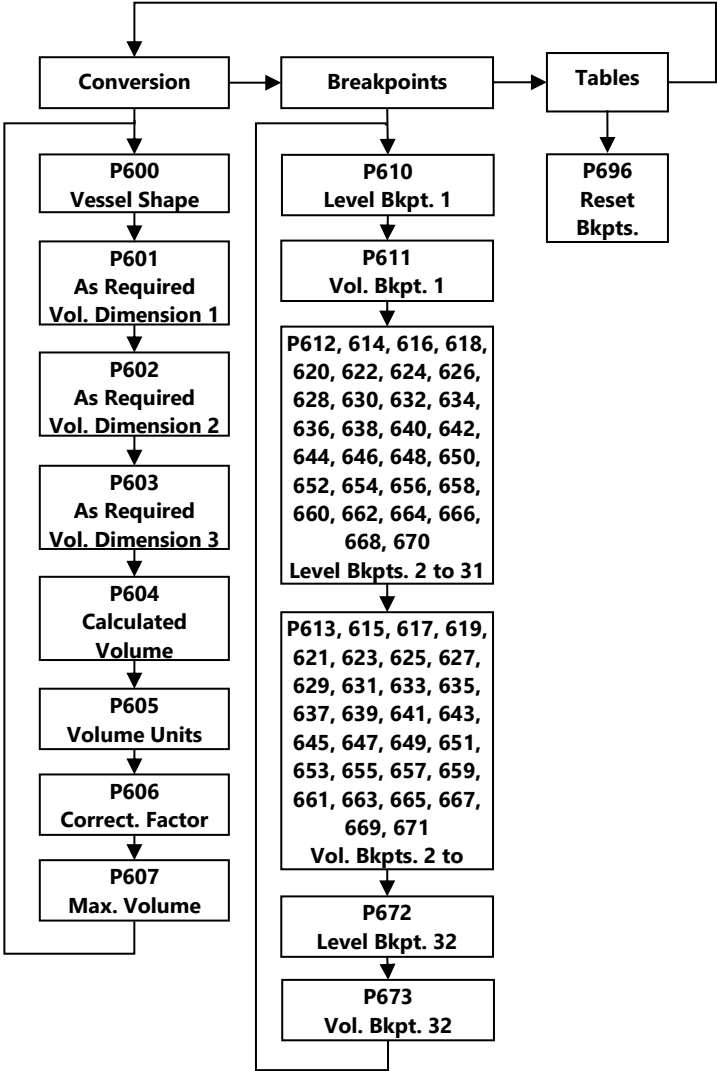

Display Menu

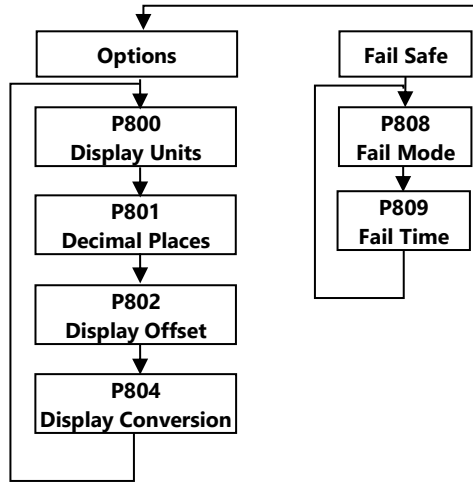

mA Output Menu

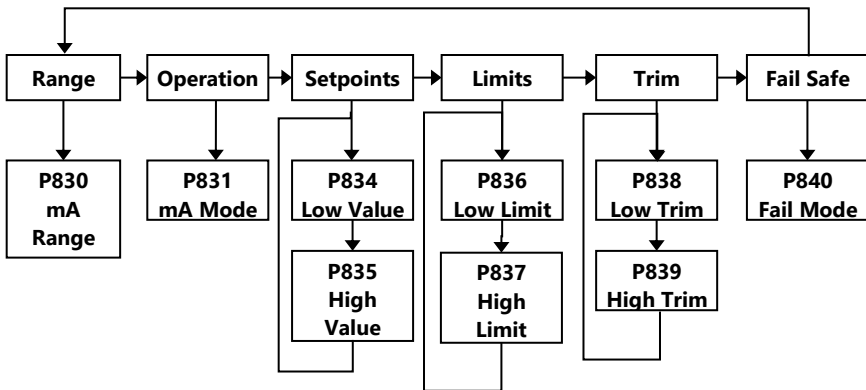

Stability Menu

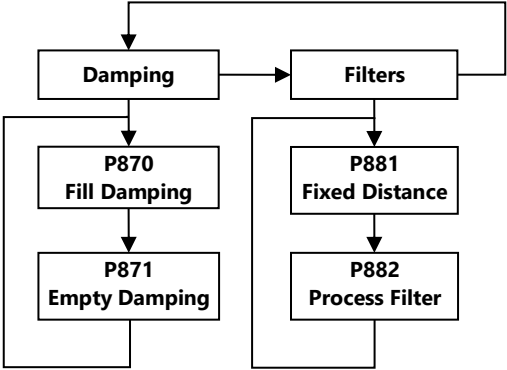

Echo Processing Menu

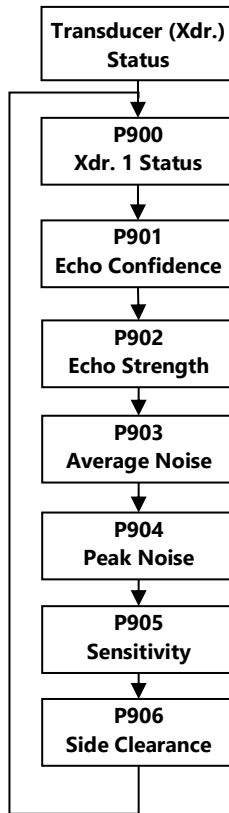

System Menu

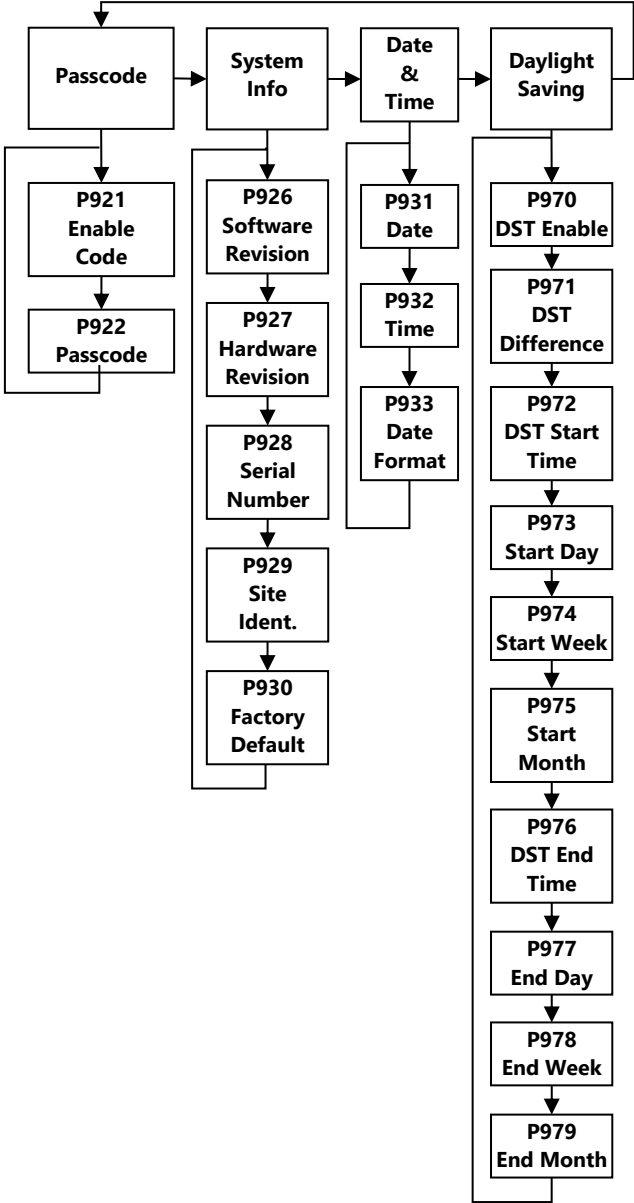

Test Menu

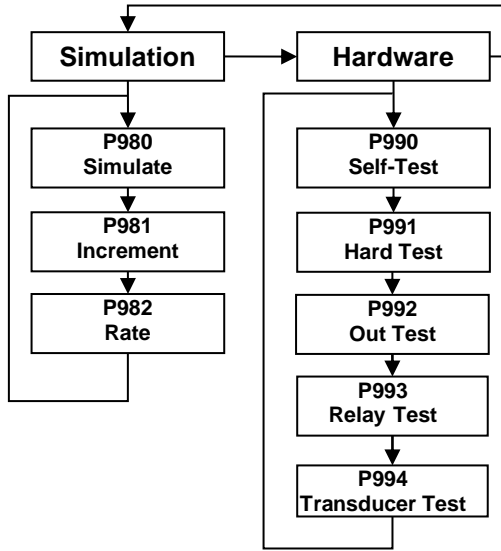

Parameter Listing

This section describes all the parameters. Any parameter can be reset to its default, by pressing the  hot key, whilst in program mode.

Application Parameters

Operation

P100 Mode of Operation

This parameter sets the mode of operation, when in run mode, and can be set to one of the following:

OPTION	DESCRIPTION
1 = Distance (Default)	Display and Output relative to the distance from the transducer to the surface.
2 = Level	Display and Output relative to how full the vessel is.
3 = Space	Display and Output relative to how empty a vessel is.
5 = Volume	Display and Output relative to volume of material in the vessel.

P101 Transducer

This parameter should be set to the transducer being used with the unit, and can be set to one of the following:

OPTION	DESCRIPTION
1 = dB3	Transducer is a dB3. Range 0.410 to 9.843 feet
2 = dB6 (Default)	Transducer is a dB6. Range 0.984 to 19.685 feet
3= dB10	Transducer is a dB10. Range 0.984 to 32.808 feet
4= dB15	Transducer is a dB15. Range 1.640 to 49.213 feet
5= dB25	Transducer is a dB25. Range 1.969 to 82.021 feet
6 = dB40	Transducer is a dB40. Range 3.937 to 131.234 feet
7 = dB56	Transducer is a dB56. Range 0.656 to 19.685 feet
*9 = dBR16	Transducer is a mmWave radar. Range 0.252 to 52.49 feet
*10 = dBR8	Transducer is a mmWave radar. Range 0.252 to 26.25 feet

***Please consult Pulsar for versions of compatible firmware that the mmWAVE is available in.**

P102 Material

This parameter should be set to the type of material being monitored

OPTION	DESCRIPTION
1 = Liquid	Use for liquids and flat solids
2 = Solid	Solid material that is heaped at an angle
3 = Closed Tank	Use for applications within a closed vessel or where a secondary echo response may become focused to create a larger echo than the first.

Dimensions

P104 Measurement Units

This parameter sets the units you want to use for programming and display

OPTION	DESCRIPTION
1 = metres	All units of measure are METRES
2 = cm	All units of measure are CENTIMETRES
3 = mm	All units of measure are MILLIMETRES
4 = feet (Default)	All units of measure are FEET
5 = inches	All units of measure are INCHES

P105 Empty Level

This parameter is to be set to the maximum distance from the face of the transducer to the **empty point**, in **P104 Measurement Units**.

Important Notice

When changing the Empty Distance (P105) you can also recalculate the values for the Span so that it equals the empty distance (P105) minus Near Blanking (P107) and the Relay Setpoints, so that they remain at the same percentage values of the empty distance as they were before you changed the empty distance (P105). You will be asked the question "Recalculate Span?" if you choose yes (enter 1), then the span will be recalculated. Any other answer will leave the span at its original value. You will then be asked if you want to "Recalculate Setpoints?", if you choose Yes (enter 1), then all Relay Setpoints will be recalculated as a percentage of the new empty distance. Any other answer will leave the setpoints at their original values.

P106 Span

This parameter should be set to the maximum distance from the **Empty Level (P105)** to the maximum material level. It is automatically set to be equal to the **Empty Level (P105)** less the **Near Blanking distance (P107)** when you set the empty level.

P107 Near Blanking

This parameter is the distance from the face of the transducer that is not measurable, and is pre-set to the minimum value dependant on the Xducer (P101) selected. It should not be set to less than this figure, but can be increased, typical to ignore close in obstructions.

OPTION	DESCRIPTION
P101 = dB3	Default Blanking Distance = 0.410 feet
P101 = dB6	Default Blanking Distance = 0.984 feet
P101 = dB10	Default Blanking Distance = 0.984 feet
P101 = dB15	Default Blanking Distance = 1.640 feet
P101 = dB25	Default Blanking Distance = 1.969 feet
P101 = dB40	Default Blanking Distance = 3.937 feet
P101 = dB56	Default Blanking Distance = 0.656 feet
P101 = dBR16	Default Blanking Distance = 0.252 feet
P101 = dBR8	Default Blanking Distance = 0.252 feet

***The signal emanates from the curved face of the Radar, but for the purposes of measurement it is taken from the drip shield.**

P108 Far Blanking Distance

This is the distance (as a **percentage** of **empty level P105**) beyond the empty point that the unit will be able to measure, and by **default** is pre-set to **20%** of the **empty level**.

If the surface being monitored can extend beyond the **Empty Level (P105)** then the far blanking distance can be increased to a maximum of 100% of empty level.

This parameter is always entered as a % of empty level.

Remote Alarm

When a Modem is connected to the Blackbox, via the RS232 port, (Consult Pulsar or your local distributor for further details), the following parameters are used to set up the BlackBox so that when the level reaches a specific alarm point, as determined by the setting of the relay(s) the unit will dial and connect to a remote telephone number to provide details of the event.

P985 Tel. No.1

This parameter is used to enter the number of '0's that appear at the beginning of the telephone number to be dialled that is to receive the message.

OPTION	DESCRIPTION
0 = None	No '0's present at the beginning of the telephone number to be dialled.
1 = Add 0 (Default)	1 '0' present at the beginning of the telephone number to be dialled.
2= Add 00	2 '0's present at the beginning of the telephone number to be dialled.

P986 Tel. No2

This parameter is used to enter to enter the next 6 digits, following the '0's, of the telephone number to be dialled. If there are less than 6 digits following the '0's then just enter the digits required, if there are more than 6 digits following the '0's then enter the first 6 digits and then proceed to P987 and enter the remaining digits.

P987 Tel. No3

This parameter is used to enter any remaining digits of the telephone number to be dialled after completion of P985 and P986 above.

Example

Telephone number to be dialled is: 0 1234 123456

P985 Tel. No. 1 = 1(One '0' at the beginning of the telephone number)

P986 Tel. No. 2 = 123412 (The next 6 digits following the '0's).

P987 Tel. No. 3 = 3456 (Remaining digits of telephone number).

P988 Call Type

This parameter determines what type of connection is made via the modem.

OPTION	DESCRIPTION
0 = Off (Default)	Remote alarm function is disabled
1 = Add 0	This option initiates a connection to a remote modem/computer which will then allow remote communication with the unit. Please consult Pulsar or your local distributor for further details.
2= Add 00	This option initiates a predetermined message which is sent to the remote telephone number detailing date and time the alarm was initiated, the site ID, alarm condition and level at the time the alarm was initiated.

SMS Time

The following parameters determine when and how often a SMS message is to be sent.

P995 SMS Interval

This parameter determines how often a SMS message will be sent. If the time interval is set at '0.00 mins.' then a SMS message will only be sent when an alarm condition occurs, when the time interval is set to anything other than zero, then a SMS message will be sent at the relevant interval detailing the current level and/or any alarm condition present at that time.

Entered in minutes. Min = 0.000, Max = 1440mins. Default = 0.00 mins.

P996 Start Time

Sets the time at which the SMS Interval is to Start.

Entered as time. Min = 00:00, Max = 23:59 Default = 00:00

P997 Stop Time

Sets the time at which the SMS Interval is to Stop.

Entered as time. Min = 00:00, Max = 23:59 Default = 23:59

P998 SMS Days

This parameter will determine on which days the SMS message is active and is entered as a Boolean value equating to the total of the days that the SMS message is required to be active.

Mon	Tue	Wed	Thu	Fri	Sat	Sun
1	2	4	8	16	32	64

Add together any combination up to a maximum of 127 (every day).

Examples:

21 = Mon, Wed, Fri.,

31 = Mon to Fri.,

10 = Tue and Thu.

Relay Parameters

All relay related parameters are prefixed with a **2****.

The second digit of the three-figure parameter number denotes the relay number as follows:

21* parameters for Relay 1

22* parameters for Relay 2

The third digit selects specific parameters for the setting up of the relays, which can be selected individually and results in the following parameter numbers for each relay.

Relay 1 **210** to **218**

Relay 2 **220** to **228**

P210, P220 - Relay Type

This parameter defines what type each relay should be, see the table below or available options.

OPTION	DESCRIPTION
0 = Not in Use (Default)	Relay not in use programmed.
1 = Alarm	Relay is programmed as an alarm relay, which will de-energise ON, and energise OFF. This will ensure an alarm is raised if the power fails to the unit.
2 = Control	Relay is programmed as a control relay, which will energise ON, and de-energise OFF.

Alarms

P210, P220 = 1 (Alarm)

The **second parameter** for each relay determines the **function** of the alarm.

P211, P221 - Relay Function

This parameter defines what **function** the **alarm** will respond to as follows.

OPTION	DESCRIPTION
0 = Off (Default)	Relay will not operate
1= Level	Alarm is based on the level in the vessel, and the type of level alarm (P212, 222) and two setpoints must be set (P213, 223 & P214, 224). Setpoints are entered in Display Units as referenced to Empty Level.
2= Temperature	Alarm is based on the temperature, and the type of temperature alarm (P212, 222) and two setpoints must be set (P213, 223 & P214, 224). The temperature used depends on the temperature source selected (P852). Setpoints are entered in oC.
3= Loss of Echo	Alarm is raised if the Failsafe Timer (P809) expires. No setpoints are required.
4= Loss of Clock	Alarm is raised if the real time clock fails. No setpoints are required.

Note that the loss of echo and loss of clock will also be shown on the display as "LOST ECHO" and "LOST CLOCK" respectively.

P212, 222 - Relay Alarm ID

When P211, P221 = 3 (Loss of Echo) or 4 (Loss of Clock). This parameter has no function and will not be displayed

When P211, P221 = 1 or 2

This parameter defines which alarm type, the relay should respond to, as follows:

OPTION	DESCRIPTION	SETPOINTS
1 = General (Default)	Relay goes "ON" when the value reaches the ON setpoint and goes "OFF" when the value reaches the OFF setpoint.	P213, 223 is ON Setpoint. P214, 224 is OFF Setpoint
2 = High	Relay goes "ON" when the value rises to the ON setpoint and goes "OFF" when the value lowers to the OFF setpoint.	ON > OFF Relay Setpoints P213, 223 and P214, 224 Setpoints, can be set in any order as the unit 'knows' that you are setting a high-level alarm.
3 = Hi-Hi	Same as 2 = High, but different identifier.	
4 = Low	Relay goes "ON" when the value lowers to the ON setpoint and goes "OFF" when the value rises to the OFF setpoint.	ON < OFF Relay Setpoints P213, 223 and P214, 224. Setpoints, can be set in any order as the unit 'knows' that you are setting a low-level alarm.
5 = LoLo	Same as 4 = Low, but different identifier.	
6 = In bounds	Relay goes "ON" if value is inside the zone between the two setpoints.	Relay Setpoints, P213, 223 and P214, 224 can be set in any order as the unit 'knows' that you are setting an inbounds alarm.
7 = Out of bounds	Relay goes "ON" if value is outside the zone between the two setpoints.	Relay Setpoints P213, 223 and P214, 224 can be set in any order as the unit 'knows' that you are setting an out of bounds alarm.

The **fourth parameter** and the **fifth parameter** for each relay set the **Alarm "ON"** and **"OFF"** points. For a **high alarm**, the **"ON"** is set **higher than "OFF"**. For **low alarm** then **"ON"** is set **lower than "OFF"**. See the appropriate **alarm ID**, table (P212, 222) for further information.

When P211, P221 = 3 (Loss of Echo) or 4 (Loss of Clock)

This parameter has no function and will not be displayed.

When P211, P221 = 1 (Level) or 2 (Temperature)

P213, P223 - Relay Setpoint 1

Determines the "ON" or "OFF" point for the alarm according to the ID selected.

P214, P224 - Relay Setpoint 2

Determines the "ON" or "OFF" point for the alarm according to the ID selected.

Important Notice

Setpoints are entered in values according to the **function** selected.

Level - entered in Display Units as referenced to Empty Level.

Temperature - entered in °C.

See the appropriate **alarm function**, table (P211, 221) for further information.

Control

P210, P220 = 2 (Control)

When a relay is being set up as a **control** relay, the **second parameter** that will be displayed in the menu determines its **function**.

P211, P221 - Relay Function,

This function is used, where it is required to **energise** the relay to switch a device, such as a pump, **ON** and **de-energise** the relay to switch the device **OFF**.

OPTION	DESCRIPTION
0 = Off	Relay is always de-energised
1 = General	Relay will energise "ON" as set in Relay Setpoint 1 (P213, 223). And turns "OFF", de-energises , as set in Relay Setpoint 2 (P214, 224).

Important Notice

A control relay is started and stopped at the "ON" and "OFF" setpoints. To **control down** (reduce level) then set "ON" higher than "OFF". To **control up** (increase level) then set "ON" lower than "OFF". For relay 1 "ON" is P213, "OFF" is P214 and for relay 2 "ON" is P223, "OFF" is P224.

The **third parameter** determines if the control is fixed or alternating.

P212, 222 Relay Control ID

P210, 220 = 2 (Control)

P211, 221 = 1 (General)

OPTION	DESCRIPTION
1 = Fixed	All control devices are used to assist each other (run at the same time) and each device has its own setpoints. ('ON' P213, 223 & 'OFF' P214, 224).
2 = Alternate	All control devices are used to assist each other (run at the same time). With each device having its own setpoints, ('ON' P213, 223 & 'OFF' P214, 224) but each time all devices have stopped, then the setpoints are sequentially rotated between the devices to ensure equal usage.

The **fourth parameter**, and **fifth parameter**, are set to determine the switch points, "ON" and "OFF" for the relay. See **control function**, table (P211, 221, 231) for further information.

P213, P223 - Relay Setpoint 1

This parameter determines the "ON" point for the control relay.

Relay Setpoints are entered in values of Measurement Units (P104).

P214, P224 - Relay Setpoint 2

This parameter determines the "OFF" point for the control relay.

Relay Setpoints are entered in values of Measurement Units (P104).

Common Parameters

P217, P227 - Relay Closures

This parameter displays the number of times the relay has activated since the relay has been in use. It can be reset with any value.

P218, P228 - Relay Fail Safe

The unit has a general fail-safe parameter **P808**. However, this can be overridden so that each individual relay has its own independent fail-safe mode.

This parameter determines what the relay will do in the event of the **Failsafe Time (P809)** expiring.

OPTION	DESCRIPTION
0 = Default	Relay assumes system default mode P808
1 = Hold	Relay remains in its current state
2 = De-energise	Relay will De-energise
3 = Energise	Relay will Energise

Data Logs

The data log parameters contain the following information.

Temperature

The following parameters give information on temperature conditions seen by the **Temperature source (P852)** in °C. All these parameters are read only and cannot be changed, though if P852 is changed they will be reset.

P580 Minimum Temperature

This parameter displays the minimum temperature recorded.

P581 Minimum Temperature Date

This parameter displays the date when the minimum temperature was recorded.

P582 Minimum Temperature Time

This parameter displays the time when the minimum temperature was recorded.

P583 Maximum Temperature

This parameter displays the maximum temperature recorded.

P584 Maximum Temperature Date

This parameter displays the date when the maximum temperature was recorded.

P585 Maximum Temperature Time

This parameter displays the time when the maximum temperature was recorded.

P586 Current Temperature

This parameter displays the current temperature.

Volume



Only available on BlackBox 130D, fitted with optional LCD display and integral keypad and provides a variety of volume calculation features, **with 11** pre-programmed **vessel shapes**. See **Vessel Shape (P600)** for more information. For each vessel you will need to know the **dimensions (P601-603)** in **Measurement Units (P104)** which are required to calculate the **volume (P604)** which will be displayed in the selected **Volume Units (P605)**.



If your vessel shape does not correspond with any of the pre-programmed vessel shapes, then you can use the **universal calculations**. For this you will need a level/volume graph or chart provided by the vessel manufacturer or you can create one based on the dimensions of the vessel. You can enter up to 32 pairs of breakpoints, and the more you enter, the greater accuracy of the volume calculation will be.

*Conversion**P600 Vessel Shape*

This parameter determines which vessel shape is used when utilising "Volume Conversion".

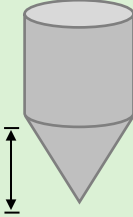
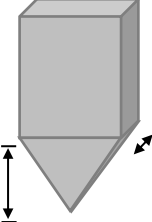
The choices are as shown in the table below, along with the **dimensions** that are required to be entered (**P601-P603**).

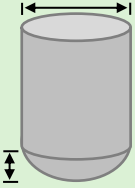
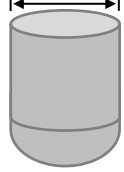
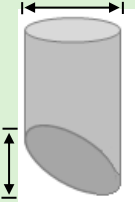
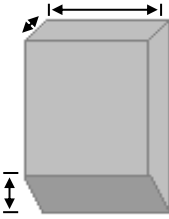
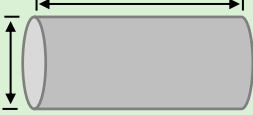
VESSEL SHAPE	P600 VALUE DESCRIPTION	DIMENSIONS
	P600 = 0 (Default) Cylindrical Flat Base	Cylinder diameter
	P600 = 1 Rectangular Flat Base	Width and Breadth
	P600 = 2 Cylindrical Cone Base	Cylinder diameter and height of bottom
	P600 = 1 Rectangular Flat Base	Width and Breadth

VESSEL SHAPE	P600 VALUE DESCRIPTION	DIMENSIONS
	P600 = 4 Parabola Base	Cylinder diameter and height of bottom
	P600 = 5 Flat Sloped Base	Cylinder diameter
	P600 = Flat Sloped Base	Cylinder diameter and height of bottom
	P600 = 7 Rectangular flat sloped base	Width and breadth of rectangular section and height of bottom
	P600 = 8 Horizontal cylinder with flat ends	Cylinder diameter and tank length
	P600 = 9 Horizontal cylinder with parabolic ends	Cylinder diameter, length of one end and section, and tank length

VESSEL SHAPE

P600 VALUE DESCRIPTION

DIMENSIONS

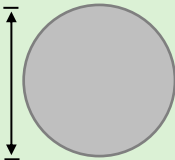
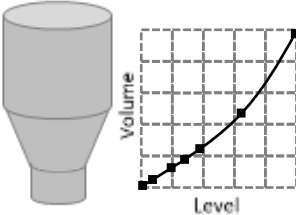
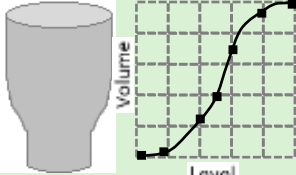
	<p>P600 = 10 Sphere</p>	<p>Sphere diameter</p>
	<p>P600 = 11 Universal linear</p>	<p>No dimensions required as level, and volume breakpoints are used</p>
	<p>P600 = 12 Universal curved</p>	<p>No dimensions required as level, and volume breakpoints are used</p>

P601-P603 Vessel Dimensions

These three parameters are used to enter the dimension required to calculate the volume. The dimensions required are as shown below and are entered **Measurements Units (P104)**.

VESSEL SHAPE	P601	P602	P603
P600 = 0 Cylindrical flat base	Cylinder Diameter	Not required	Not required
P600 = 1 Rectangular flat base	Not required	Width of rectangle	Breadth of rectangle
P600 = 2 Cylindrical cone base	Height of base	Width of rectangle	Not required
P600 = 3 Rectangular pyramid base	Height of base	Width of rectangle	Breadth of rectangle
P600 = 4 Cylindrical parabola base	Height of base	Cylinder diameter	Not required
P600 = 5 Cylindrical half sphere base	Cylinder diameter	Not required	Not required
P600 = 6 Cylindrical flat sloped base	Height of base	Cylinder diameter	Not required
P600 = 7 Rectangular flat sloped base	Height of base	Width of rectangle	Breadth of rectangle
P600 = 8 Horizontal cylinder flat ends	Length of cylinder	Cylinder diameter	Not required
P600 = 9 Horizontal cylinder parabolic ends	Length of cylinder	Cylinder diameter	Length of one end
P600 = 10 Sphere	Sphere diameter	Not required	Not required

P604 Calculated Volume

This parameter displays the maximum volume that has been calculated by the BlackBox and is a Read Only parameter. The volume displayed will be shown in cubic meters and is the total volume available between **empty level (P105)** and 100% of **span (P106)**.

P605 Volume Units

This parameter determines the units that you wish to display, for volume conversion. It is used in conjunction with **P607 (maximum volume)**, and the units are shown on the display (subject to P810). The choices are:

OPTION	DESCRIPTION
0 = No units	Volume will be totalised with no units
1 = Tons	Volume will be totalised in Tons
2 = Tonnes	Volume will be totalised in Tonnes
3 = Cubic metres	Volume will be totalised in Cubic metres
4 = Litres	Volume will be totalised in Litres
5 = UK Gallons	Volume will be totalised in UK Gallons
6 = US Gallons	Volume will be totalised in US Gallons
7 = Cubic Feet (Default)	Volume will be totalised in Cubic Feet
8 = Barrels	Volume will be totalised in Barrels
9 = lbs (pounds)	Volume will be totalised in lbs (pounds)

P606 Correction Factor

This parameter is used to enter a correction factor, when required, such as the specific gravity of the material so that the volume calculated is relative to the actual amount of material that can be contained between **empty level (P105)** and 100% of **span (P106)**. **Default = 1**

P607 Max Volume

This parameter displays the actual maximum volume that has been calculated by the BlackBox, i.e., **P604 Calculated Volume x P606 Correction Factor**, and is a Read Only parameter. The volume displayed will be shown in **P605 Volume Units** and is the total volume available between **empty level (P105)** and 100% of **span (P106)**.

Breakpoints

P610-P673 Level/Volume Breakpoints

These parameters are used to create a profile of the vessel when **P600=11 (universal linear)** or **P600=12 (universal curved)**. You should enter breakpoints in pairs, a reading for level and its corresponding volume. The more pairs you enter, the more accurate the profile will be. In the case of universal linear, then enter the level/volume at each of the points where the vessel changes shape. In the case of the universal curved, enter values around each arc tangent, as well as at the top and bottom.

You must enter at least two pairs, and you can enter up to 32 pairs.

Universal Linear (P600=11)

This volume calculation creates a linear approximation of the level/volume relationship and works best if the vessel has sharp angles between each section.

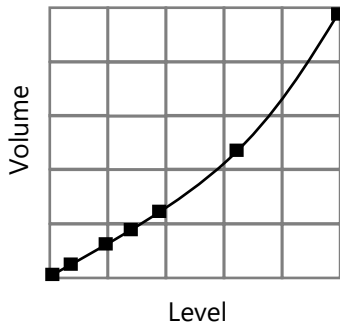
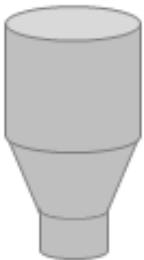

You should enter a level/volume breakpoint for each place where the vessel changes direction, and numerous where the section is slightly curved (mostly linear but has got a small arc). You can enter any number of pairs between 2 and 32.

Universal Curved (P600=12)

This volume calculation creates a curved approximation of the level/volume relationship, and works best if the vessel is non-linear, and there are no sharp angles.

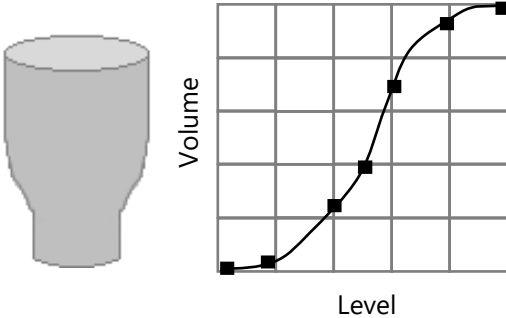

You should enter 2 level/volume breakpoints at the minimum and maximum levels, and several for each place where the vessel has got an arc. You can enter any number of pairs between 2 and 32.

Tables

P696 Reset Breakpoints

This parameter allows the resetting, to the default value, of all previously set breakpoints (P610-673), without having to access them individually. When it is necessary to reset or amend breakpoints this can be achieved by directly accessing the desired parameter (P610-673) and changing as required.

P697 Number of Breakpoints Set

This parameter allows you to review the number of breakpoints that have been set, without the need to access each individual one in turn, this is a "Read Only" parameter and no values can be entered.

Display Parameters

Options

P800 Display Units

This parameter determines whether the reading displayed is in **Measurement Units (P104)**, or as a **percentage of span**.

OPTION	DESCRIPTION
1 = Measured (Default)	Display is in selected unit's dependant on Mode (P100)
2 = Percentage	Display is in Percentage of Span dependant in Mode (P100)

P801 Decimal Places

This parameter determines the number of decimal places shown on the display of the PC Programming Software (standard), handheld Calibrator (optional) when connected, or on the on-board display (optional), while the BlackBox is in the run mode. Minimum = 0 (No decimal places), Maximum 3 = (3 decimal Places). **Default = 2 (2 decimal Places)**.

P802 Display Offset

The value of this parameter is added to the reading before it is displayed, in **Measurement Units (P104)**. It does not affect the relay setpoints or the mA output, only the reading on the display itself.

You could use this feature if for example you wanted to reference the reading to sea level, where you would enter the distance between **Empty level (P105)** and sea level. If the empty level point is below sea level, then enter a negative value.

P804 Display Conversion

The reading is multiplied by the value of the parameter before being displayed. The default is 1.0, and will be applied when **P802 Display Offset** is set to a different value other than its default value of '0'.

Failsafe

P808 Fail-safe Mode

By default, if a fail-safe condition occurs, then the display and the output are held at their last **known** values until a valid reading is obtained.

If required, then you can change this so that the unit goes to **high** (100% of span), or **low** (empty) as follows:

OPTION	DESCRIPTION
1 = Known (Default)	Remain at the last known value
2 = High	Will fail to the high value (100% of Span).
3 = Low	Will fail to the low value (empty)

Important Notice

In the event of a fail-safe condition occurring, the display and Output can be configured to fail to a condition which is independent of each other. To set independent Output Failsafe see P840.

P809 Fail-safe Time

In the event of a fail-safe condition the failsafe timer determines the time before fail-safe mode is activated. **Default = 1min.**

If the timer activates, the unit goes into **fail-safe**, as determined by **P808 (Display)**, **P218, 228 (Relays)** and **P840 (Output)**. When this happens, if the PC Handheld Communicator or the optional Handheld Communicator, are connected to the unit, or the optional on-board display is fitted, you will see the message "**Failed Safe!**" on the display, along with a message explaining why (lost echo or transducer fault, for example)

When a valid measurement is obtained then the display and output will be restored, and the timer is reset.

mA Output Parameters

Range

P830 Output Range

This parameter determines the range of the mA output, from the following.

OPTION	DESCRIPTION
0 = Off	Output disabled
1 = 0 to 20mA	Output directly proportional to the output mode (P831) , so if the reading is 0% the output is 0 mA. If the reading is 100% the output is 20 mA.
2 = 4 to 20mA (Default)	output directly proportional to the output mode (P831) , so if the reading is 0% the output is 4 mA. If the reading is 100% the output is 20 mA.
3 = 20 to 0mA	output inversely proportional to the output mode (P831) , so if the reading is 0% the output is 20 mA. If the reading is 100% the output is 0 mA.
4 = 20 to 4mA	output inversely proportional to the output mode (P831) , so if the reading is 0% the output is 20 mA. If the reading is 100% the output is 4 mA

Operation

P831 Output Mode

This parameter determines the output mode of the mA output, from the following.

OPTION	DESCRIPTION
0 = Default	mA output relative to Mode P100
1 = Distance	mA output relative to distance .
2 = Level	mA output relative to level .
3 = Space	mA output is relative to space .
5 = Volume	mA output is relative to volume .

Setpoint

By **default**, the mA output will represent the **empty (0 or 4mA)** dependant on **(P830) Out Range** and **100%** of the operational **span (20mA)**, but you may wish to have the output represent a section of the operational span. For example, the application has an operational span of 6 metres, but **output** is to **represent empty (0 or 4mA)** dependant on **(P830) Out Range** to a **level of 5 metres (20mA)**. If so P834 (Low Level) should be set to 0.00 metres and P835 (High Level) should be set to 5 metres.

P834 Output Low Level

This parameter sets, in **Measurement Units (P104)**, the value of 'level', 'distance' or 'space', depending on the selected **Out Mode (P831)** at which the low mA output will occur **(0 or 4mA)** dependant on **(P830) Out Range**
Default = 0.000 feet

P835 Output High Level

This parameter sets, in **Measurement Units (P104)**, the value of 'level', 'distance' or 'space', depending on the selected **Out Mode (P831)** at which the high mA output will occur **(20mA)**. **Default = 19.685 feet**

Limits

P836 Output Low Limit

This parameter sets the lowest level that the mA output will drop to, the default is 0mA, but you can override this if the device you connect to cannot for example accept less than 2mA, yet you want to use the 0-20mA range.
Default = 0.00mA

P837 Output High Limit

This parameter sets the highest level that the mA output will rise to, the default is 20 mA, but you can override this if the device you connect to cannot for example accept more than 18 mA, yet you want to use the 0-20 mA range. **Default = 20.00mA**

Trim

P838 Output Low Trim

If the device you are connected to is not calibrated, and not showing the correct **low value** (reading), then you can trim it using this parameter. You can either type in the offset directly or use the arrow keys to move the output up and down until you get the expected result (reading) on the device that is connected.

P839 Output High Trim

If the device you are connected to is not calibrated, and not showing the correct **high value** (reading), then you can trim it using this parameter. You can either type in the offset directly or use the arrow keys to move the output up and down until you get the expected result (reading) on the device that is connected.

Failsafe

P840 Output Fail-safe Mode

This parameter determines what happens to the output in the event of the unit going into fail-safe mode. The **default** is to do the same as the **system fail-safe (P808)**, but this can be overridden to force the output to an independent fail-safe mode as follows:

OPTION	DESCRIPTION
0 = Default	Output will fail as per P808
1 = Hold	Output will retain its last known value
2 = Low	Output will fail to its low condition.
3 = High	Output will fail to its high condition (20mA maximum)
4 = Very Low	Output will fall to its lowest or fault condition of 2mA for 4-20 range or 0mA for 0-20 range.
5 = Very High	Output will fail to its highest or fault condition of greater than 20mA (22mA maximum)

Compensation Parameters

Offset

P851 Measurement Offset

The value of this parameter is added to the measured distance, in **Measurement Units (P104)**.

This Offset will be added to the level, as derived from the transducer, and will affect everything including the reading on any display in use, relay setpoints and the output.

Temperature

P852 Temperature Source

This parameter determines the source of the temperature measurement. By **default**, it is set to automatic (**P852=1**), which will automatically detect if a temperature sensor is available from the transducer. If for any reason, no temperature input is received, then the **Fixed Temp** value is used, as set by **P854**.

The temperature source can be specifically set as follows:

OPTION	DESCRIPTION
1 = Automatic (Default)	Will automatically select transducer temperature sensor, if available, or fixed temperature (P854) if no temperature sensor found.
2 = Fixed	Always uses fixed temperature (P854)

P854 Fixed Temperature

This parameter sets the temperature, in degrees centigrade to be used if **P852 (Temperature Source) =2**. Default = 20°C.

Stability Parameters

Damping

Damping is used to damp the display, to enable it to keep up with the process but ignore minor surface fluctuations.

P870 Fill Damping

This parameter determines the maximum rate at which the unit will respond to an increase in level. It should be set slightly higher than the maximum vessel fill rate. **Default = 32.8084 ft/minute**

P871 Empty Damping

This parameter determines the maximum rate at which the unit will respond to a decrease in level. It should be set slightly higher than the maximum vessel empty rate. **Default = 32.8084 ft/minute**

Filters

The following parameters can be used to filter out unwanted changes of level caused by a 'rippled' or agitated surface.

P881 Fixed Distance

This parameter determines the width of gate to be used in tracking an echo and under normal circumstances will not require changing, but it can be increased in the cases where the surface is moving extremely fast (more than 32.8084 ft/min) to ensure smooth processing of the changing level.

P882 Process Filter

This parameter determines the number of 'cycles' that will be taken before a change in level is processed and the display updated.

OPTION	DESCRIPTION
1 = Fast	level will be updated every cycle
2 = Medium	level will be updated every 8 cycles
3 = Slow (Default)	level will be updated every 16 cycles

Echo Processing Parameters

Transducer Status

P900 Transducer Status

This parameter shows the current state of the transducer. The value means the following.

OPTION	DESCRIPTION
0= OK (Default)	Transducer working correctly.
1= Disabled	Transducer is not being used
2= Stuck High	Indicates that the power and signal lines on the transducer terminals are crossed over, or the signal line is shorted to earth.
3= Not Found	No transducer is detected.

P901 Echo Confidence

This parameter displays the most recent echo confidence from the transducer. It is useful to help find the best mounting location for the transducer, where you should aim to get the highest figure. It is a percentage of confidence that the echo reporting the level is the correct one.

P902 Echo Strength

This parameter shows the most recent echo strength figure for the transducer, where a higher figure indicates a better returned echo.

P903 Average Noise

This is the mean noise reading for the transducer. It is measured while the transducer is not firing, and gives an indication of the average amount of electrical noise present on the cabling.

P904 Peak Noise

This is the peak noise reading for the transducer. It is measured while the transducer is not firing, and gives an indication of the maximum amount of electrical noise present on the cabling.

P905 Sensitivity

This parameter determines the sensitivity of the unit. Please consult Pulsar for further information and assistance on changing the value of this parameter.

P906 Side Clearance

This parameter is used to set the distance by which the DATEM trace will "stand-off" from around unwanted echoes such as obstructions. Please consult Pulsar for further information and assistance on changing the value of this parameter.

System Parameters

Passcode

P921 Enable Code

Enables the passcode (**P922**), which means the passcode must be entered to go into program mode. If **disabled** (set to **0**), then no passcode is required, and ENTER is used to enter program mode. **Default = 1 (Enabled)**

P922 Passcode

This is the passcode that must be used to enter program mode. The **default** is **1997**, but this can be changed to another value from 0 to 9999.

System Information

The following three parameters do not affect how the unit performs, but details contained within them may be required, by Pulsar, when making technical enquiries.

P926 Software Revision

This parameter will show the current software revision

P927 Hardware Revision

This parameter will show details of the current hardware revision

P928 Serial Number

This parameter will show the serial number of the unit.

P929 Site Identification

This parameter allows you to give each unit an individual reference number, for identification purposes. You can set any number between 1 and 99999.

P930 Factory Defaults

This parameter resets all parameter values to the original Factory Set values that were installed when the unit was tested before despatch to you.

To **reset** parameters, enter **1 (Yes)**, and press **ENTER**, then you will see a message "**Entr if sure**", you should press **ENTER** again. If you press any other key at this point, the parameters will not be reset, and you will see a message confirming this.

Once you have done this, program the unit, to the desired application.

Date & Time

P931 Date

This parameter shows the **current date**, in the format as set by **P933 (Date Format)** and can be reset if required.

P932 Time

This parameter shows the **current time** and can be reset if required, in the format HH: MM (24-hour format). This is set initially at the factory for UK time.

P933 Date Format

This parameter allows you to alter the format that the date is displayed to your choice of DD: MM: YY, MM: DD: YY or YY: MM: DD. The default is DD: MM: YY.

Daylight Saving Time

P970 DST Enable

When Enabled (set to 1) the internal clock will be automatically adjusted to compensate for the difference between standard time and Daylight-Saving Time.

OPTION	DESCRIPTION
0 = No	DST is disabled
1 = Yes (Default)	DST in enabled

P971 DST Difference

This parameter sets the time difference between standard time and Daylight Saving Time. The time difference is entered in HH: MM.

Default = 01:00

P972 DST Start Time

This parameter is used to set the time of day at which Daylight Saving Time will **start**, the time is entered in the format HH: MM (24-hour format).

Default = 02:00

P973 Start Day

Use this parameter to enter the day of the week (P974) that Daylight Saving Time is to **start**.

OPTION	DESCRIPTION
2 = Monday	DST will start on a Monday
3 = Tuesday	DST will start on a Tuesday
4 = Wednesday	DST will start on a Wednesday
5 = Thursday	DST will start on a Thursday
6 = Friday	DST will start on a Friday
7 = Saturday	DST will start on a Saturday
8 = Sunday (Default)	DST will start on a Sunday

P974 Start Week

This parameter will determine the week of the month (P975) in which Daylight-Saving Time is to **start**.

OPTION	DESCRIPTION
1 = Week 1	DST will start on day (P973) in the first week (P974) of the month (P975).
2 = Week 2	DST will start on day (P973) in the second week (P974) of the month (P975).
3 = Week 3	DST will start on day (P973) in the third week (P974) of the month (P975).
4 = Week 4	DST will start on day (P973) in the fourth week (P974) of the month (P975).
5 = Last (Default)	DST will start on day (P973) in the last week. (P974) of the month (P975).

P975 Start Month

This parameter is used to select the month in which Daylight-Saving Time is to **start**.

OPTION	DESCRIPTION
1 = January	DST will start during the month of January
2 = February	DST will start during the month of February
3 = March (Default)	DST will start during the month of March
4 = April	DST will start during the month of April
5 = May	DST will start during the month of May
6 = June	DST will start during the month of June
7 = July	DST will start during the month of July
8 = August	DST will start during the month of August
9 = September	DST will start during the month of September
10 = October	DST will start during the month of October
11 = November	DST will start during the month of November
12 = December	DST will start during the month of December

P976 DST End Time

This parameter is used to set the time of day at which Daylight Saving Time will **end**, the time is entered in the format HH: MM (24-hour format).

Default = 02:00

P977 End Day

Use this parameter to enter the day of the week (P978) that Daylight Saving Time is to **end**.

OPTION	DESCRIPTION
2 = Monday	DST will start on a Monday
3 = Tuesday	DST will start on a Tuesday
4 = Wednesday	DST will start on a Wednesday
5 = Thursday	DST will start on a Thursday
6 = Friday	DST will start on a Friday
7 = Saturday	DST will start on a Saturday
8 = Sunday (Default)	DST will start on a Sunday

P978 End Week

This parameter will determine the week of the month (P975) in which Daylight-Saving Time is to **end**.

OPTION	DESCRIPTION
1 = Week 1	DST will end on day (P973) in the first week (P974) of the month (P975).
2 = Week 2	DST will end on day (P973) in the second week (P974) of the month (P975).
3 = Week 3	DST will end on day (P973) in the third week (P974) of the month (P975).
4 = Week 4	DST will end on day (P973) in the fourth week (P974) of the month (P975).
5 = Last (Default)	DST will end on day (P973) in the last week (P974) of the month (P975).

P979 End Month

This parameter is used to select the month in which Daylight-Saving Time is to **end**.

OPTION	DESCRIPTION
1 = January	DST will start during the month of January
2 = February	DST will start during the month of February
3 = March	DST will start during the month of March
4 = April	DST will start during the month of April
5 = May	DST will start during the month of May
6 = June	DST will start during the month of June
7 = July	DST will start during the month of July
8 = August	DST will start during the month of August
9 = September	DST will start during the month of September
10 = October (Default)	DST will start during the month of October
11 = November	DST will start during the month of November
12 = December	DST will start during the month of December

Test Parameters

Simulation

P980 Simulate

Test mode is used to simulate the application and confirm that all parameters and relay setpoints have been entered as expected. During simulation, there is a choice of whether the relays will change state (hard simulation) or not (soft simulation), but the LED's will always switch according to how the relays have been programmed, and the output will change accordingly. If you want to test the logic of the system that the relays are connected to then select a hard simulation, but if you don't want to change the relay state, then select a soft simulation.

There are two simulation modes, **automatic** and **manual**. Automatic simulation will move the velocity up and down between minimum and maximum velocity and activate the relay and/or corresponding LED at the programmed setpoints, if you wish to change the direction of the velocity movement at any time this can be done by using the arrow keys. In manual simulation, using the arrow keys will allow you to move the velocity up and down as required. The choices for you to enter are as follows.

1. Manual soft simulation
2. Automatic soft simulation
3. Manual hard simulation
4. Automatic hard simulation

To return to program mode, press 'CANCEL' and test mode will end.

P981 Increment

By default, simulation mode will move by **0.328 feet** steps in manual simulation and by 0.328 feet/min in automatic simulation. Altering the increment can change this value.

P982 Rate

In automatic mode, the rate at which the measurement will move up and down is determined by the **Increment (P981)** and the time, **Rate (P982)** which can be changed as required. To increase the rate at which the measurement moves increase the **Increment (P981)** or decrease the **Rate (P982)**. To decrease the rate at which the measurement moves decrease the **Increment (P981)** or increase the **Rate (P982)**.

P983 Test Max

This parameter determines the maximum of the simulated measurement values.

Default = 1000

P984 Test Min

This parameter determines the minimum of the simulated measurement values.

Default = 0

Hardware

P990 Self Test

If you enter 1 for this parameter, then the unit will perform a self-test. This will confirm that the various parts of the circuitry are working correctly. You will see confirmation messages that the clock and the EEPROM are working correctly, and error messages for any parts that fail.

P991 Hard Test

When this parameter is selected, the unit will test the following in turn:

- **LED's.** Watch them change colour as shown on the display and press **ENTER** if they operate as shown.
- **Relays.** Press a numeric key, corresponding to the number of the relay you wish to test, and the relay will change state each time the key is pressed. If you press any other key, other than a valid relay number, then the test will end.
- **Segments.** All the segments on the LCD are lit up so you can see if they all work. Press **ENTER** to end the test.
- **Keys.** You should press each key to confirm it works, with a counter showing how many more keys remain un-pressed. Be sure to press the **CANCEL** key last as this will show if all keys were pressed or not. If they were not, then an error message is displayed.

P992 Output Test

This parameter will allow you to force a specified current on to the output to test any equipment that it is connected to. The figure you enter will be generated by the output.

P993 Relay Test

Press a numeric key corresponding to the number of the relay you wish to test, and the relay will change state each time the key is pressed. If you press any other key, other than a valid relay number, then the test will end.

P994 Transducer Test

Press any key on the keypad, other than 0, and the transducer will continually fire for 5 seconds, pressing 0 will terminate the test.

CHAPTER 6 TROUBLESHOOTING

This section describes many common symptoms, with suggestions as to what to do. If the issue persists, please contact your local Pulsar distributor.

SYMPTOM	WHAT TO DO
No reading being obtained, transducer not firing.	Check power supply. Check wiring to transducer.
Incorrect reading being obtained for current level.	Measure actual distance from transducer head to surface of material. Enter Program Mode and directly access P21 (Set Distance) type in the measured distance, press ENTER, when prompted press ENTER again, wait until SET displayed. Return to Run Mode, display should now update to correct reading.
Material level is consistently incorrect by the same amount.	Check empty level (P105), display offset (P802), and measurement offset (P851).
LED's change colour at relevant relay switch points but relays do not change state.	Check there is correct supply to unit.

CHAPTER 7 DISPOSAL

Incorrect disposal can cause adverse effects to the environment.

Dispose of the device components and packaging material in accordance with regional environmental regulations including regulations for electrical \ electronic products.

Transducers

Remove power, disconnect the Transducer, cut off the electrical cable and dispose of cable and Transducer in accordance with regional environmental regulations for electrical \ electronic products.

Controllers

Remove power, disconnect the Controller, and remove battery (if fitted).

Dispose of Controller in accordance with regional environmental regulations for electrical \ electronic products.

Dispose of batteries in accordance with regional environmental regulations for batteries.



 EU WEEE Directive Logo

This symbol indicates the requirements of Directive 2012/19/EU regarding the treatment and disposal of waste from electric and electronic equipment.



www.pulsarmeasurement.com

SUPPORT@PULSARMEASUREMENT.COM

Copyright © 2020 Pulsar Measurement Ltd.

Registered Address: 1 Chamberlain Square CS, Birmingham B3 3AX

Registered No.: 3345604 England & Wales

Rev 1.0